

1. GENERAL DESCRIPTION

ORBINOX RA model tilting disc check valve is an ideal solution to protect reverse flow situations in pressurized piping systems and on the pump pressure side in a wide range of media such as raw water, wastewater, drinking water, cooling water or industrial water with solid content. Reverse flows are usually produced by system shutdowns situations or surge conditions as a result of emergency operations that can cause severe damage to equipment installed in the piping systems or even the piping systems themselves. ORBINOX RA check valves are conceived to prevent these consequences.

ORBINOX RA check valves are double-eccentric wafer or flanged valves, both with cast body or fabricated body construction in sizes up to DN 2000 and for applications up to 25 bar. Our valves are designed for horizontal piping and vertical piping installations.



Fig.1 Closed tilting disc check valve

2. OPERATION

Reverse flow situation when pumps shut down and surge tanks with elevated waterheads and variable flow rates require a rapid closing cycle time to prevent damage in the pumps.

The sooner the disc closes the less time has the reverse flow to catch speed. If this happens pumps would start rotating in the wrong direction. Also, this fast backflow creates a high risk of water hammer when closing the disc. ORBINOX tilting disc check valves are designed with an external counterweight assembly that helps initiate the closing cycle when normal flow stops and before there is reverse flow, therefore it complies with the demanding fast closing time requirements. It is however equally critical to avoid the slamming of the disc against the seat to hamper a potential seat damage and big noise.

The closing cycle works as follows:

- With the valve in open position, when the water flow in the normal direction stops, the counterweight helps to initiate the movement speeding up the process from the beginning.
- When the disc approaches the closing position, the dampening process operates as follows:
 1. The main flow regulator controls the closing speed of the disc in the first 85% of the movement. In the last 15% of the closing movement, the speed is controlled by the secondary flow regulator.
 2. The main flow regulator must be adjusted to obtain a medium-high speed in the 85% of the closing movement, therefore avoiding reverse flow to catch speed.
 3. Secondary flow regulator must be adjusted to obtain a medium-low speed in the last 15% of the movement to avoid the disc slamming against the closing seat.
 4. When the flow of the pumps opens the valve, the hydraulic system has no major influence in the opening process except for internal friction of the piston seals. This pulls a small pump capacity which is restored once the disc is open.

3. DESIGN FEATURES

ORBINOX check valves are designed for specific service conditions of each individual case. The structural evaluation is performed using the finite elements method and CAD modelling systems. ORBINOX check valves are designed and tested following the international standards:

- EN 1074
- DIN 19704
- DIN 19705

ORBINOX RA tilting disc check valves are a double-eccentric design valves allowing a short closing time. The reduced closing time together with the hydraulic damping system for non-slamming closing minimizes flow reversal and therefore avoids water hammer effects that result from valve sudden closing.

The valve is designed as a metal-seated valve, with a stainless-steel overlay in the disc and a stainless steel overlay (cast carbon steel) or stainless steel ring (fabricated construction) in the body.

The design of the disc, with two attached rotation pins and two stainless steel shafts assure a low friction and high wear resistance operation. One of the shafts is extended through the body to the outside to install both the counterweight assembly and hydraulic damping system. The shafts are sized for the torques calculated for the required closing time at the maximum surge pressure.

4. VALVE CONSTRUCTION

A check valve has the following elements:

- Body
- Disc
- Shaft
- Counterweight assembly
- Hydraulic damping system

Body:

Both cast carbon steel WCB 216 A and fabricated constructions are available. Wide range of materials are also available if fabricated, from S275JR carbon steel to AISI 304, AISI 316 or, depending on the application, more special stainless steels such as duplex (2205) or superduplex (2507). Other materials available upon request.

The seat is composed of a stainless steel ring in AISI 304 welded to the inside of the body. In case of cast carbon steel bodies, an AISI 304 overlay is provided. A later machining is performed in both cases to assure an optimum closing. Other seat arrangements are also available upon request.

After the welding process, the stabilization process takes places along with the subsequent final machining. Valve bodies are designed for the mating piping flanges, both with the required flange drilling or as a wafer-type valve with the adequate outside diameter (including positioning holes).

Disc:

The disc is formed by a main deep circular disc manufactured both in carbon steel WCB 216 A and also fabricated in S275JR carbon steel or in different stainless steel grades, from AISI 304 and AISI 316 to, depending on the application, more special stainless steels such as duplex (2205) or superduplex (2507). Other materials available upon request.

An AISI 304 overlay is welded, with a alter proper machining, to the area in touch with the body seat ring.

Shaft:

The shafts are solid stainless steel AISI 630 and rotate on self-lubricating bronze bearings. The shafts are attached to the disc by keyways.

Counterweight assembly:

A counterweight assembly composed of S275JR carbon steel plates is attached to the valve shaft. The weight or number of plates are calculated based on the required closing time and service conditions.

Hydraulic damping system:

Composed of a hydraulic cylinder usually in S275JR carbon steel and an hard-chromed AISI 304 stainless steel stem, with both ports connected to a S275JR carbon steel oil tank, in a closed circuit and including a flow control system with two oil flow regulators (one for the first 85% of stroke and the other for the remaining 15%). Closing velocity is controlled by means of these two oil flow regulators.

5. CORROSION PROTECTION SYSTEM

For cast carbon steel body or fabricated carbon steel constructions, the following corrosion protection systems are used.

Steel structures permanently immersed in water:

- Shot blasting SA 2 1/2
- 50 microns polyamide cured epoxy primer
- 400 microns glass flake reinforced polyamine adduct tar free epoxy coating

Steel structures in open air:

- Shot blasting SA 2 1/2
- 50 microns polyamide cured epoxy primer
- 120 microns aliphatic acrylic polyurethane finish blue RAL 5015

6. TESTING CONDITIONS

Hydraulic tests according to EN 12266-1:

- Body test at 1,5 the working pressure
- Seat test at 1,1 the working pressure

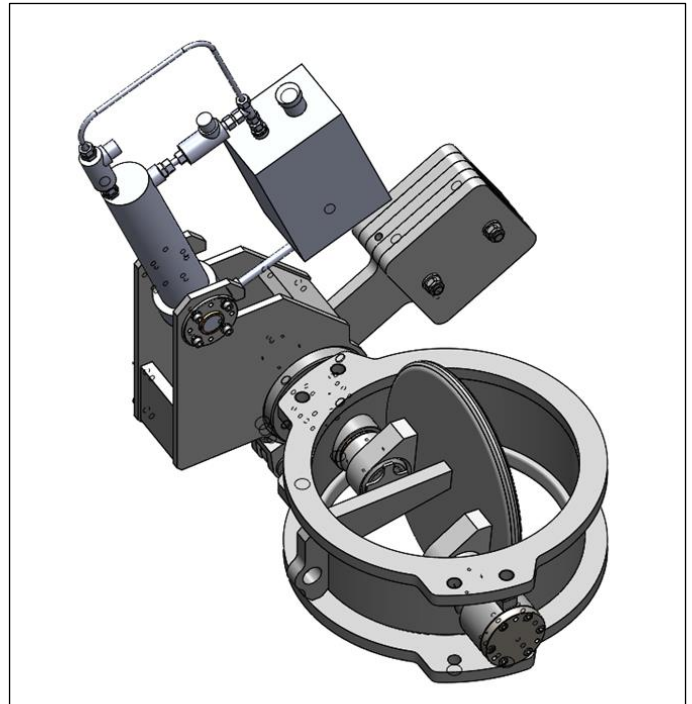

7. PARTS LIST & DRAWINGS

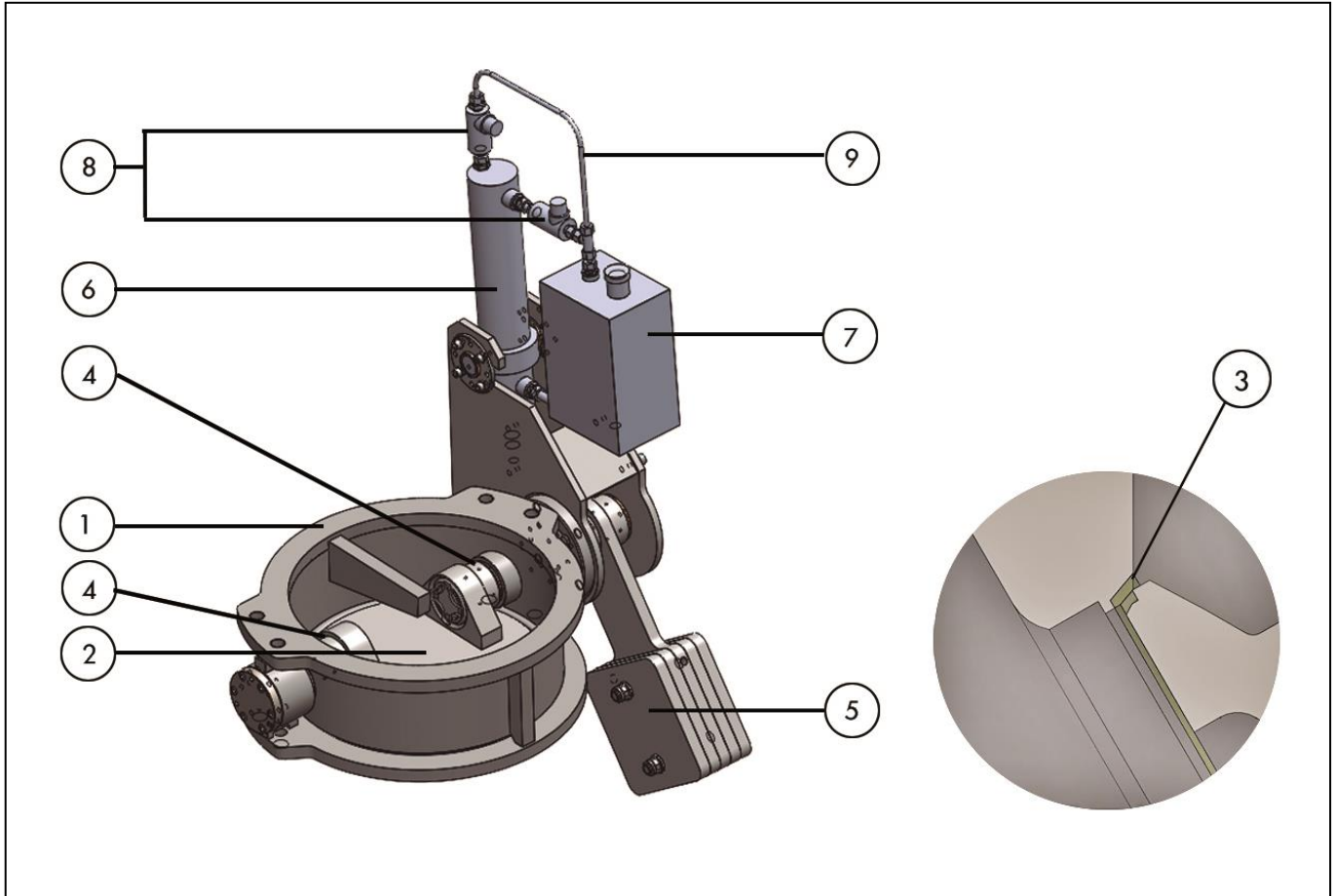

POSSIBLE MATERIAL COMBINATIONS

1. Body:	Cast: GJS400 / WCB 216 A Fabricated: S-275-JR / AISI 304 / AISI 316 / DUPLEX 2205 / SUPERDUPLEX 2507
2. Disc:	Cast: GJS400 / WCB 216 A Fabricated: S-275-JR / AISI 304 / AISI 316 / DUPLEX 2205 / SUPERDUPLEX 2507
3. Seat:	AISI 304/ AISI 316 /DUPLEX 2205 /SUPERDUPLEX 2507
4. Shaft:	AISI 630
5. Counterweight assembly:	S275JR
6. Hydraulic cylinder:	Commercial brands
7. Oil tank:	S275JR
8. Flow regulators:	Commercial brands
9. Hydraulic tubing:	AISI 304/ AISI 316

CHECK VALVE SPECIFICATIONS

CHARACTERISTICS

Nominal conduit diameter: _____ mm

Flange standard:

- PN _____
- ANSI _____
- Others: _____

Type:

- Passive (opens with pump pressure/flow) _____
- Active (opens with hydraulic cylinder) _____

External actuating-dampening system:

- Counterweight + Hydraulic damper _____
- Hydraulic damper _____

Face to face: EN 558-1, series 14...., other: _____

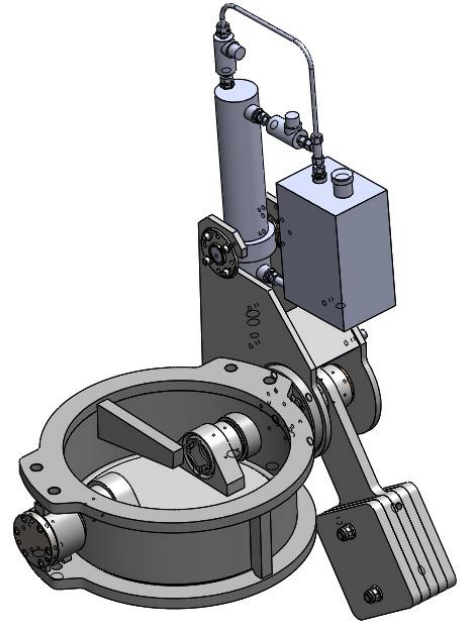

OPERATION CONDITIONS

Valve position:

- Vertical pipe
- Horizontal pipe
- Other. Please specify: _____

Maximum static pressure: _____ mwc

Maximum surge pressure: _____ mwc

Length of pipeline: _____ m

Maximum Flow: _____ m³/s

ACCESSORIES (only for active type RA)

- HPU (Hydraulic power unit)
- Electric control panel:

MATERIALS

	BODY	DISC	SEAT
WCB 216 A			
S275 JR			
AISI 304			
AISI 316			
DUPLEX (2205)			
SUPERDUPLEX (2507)			
OTHER			